



Cordless
mini sander

K 10618



SAFETY AND PRECAUTION

- 1 Consider work area environment. Do not expose tools to rain. Do not use tools in damp or wet locations – Keep work area clean and well lit. Do not use tools in the present of flammable liquids or gases.
- 2 Guard against electric shock. Avoid body contact with earthed or grounded surfaces.
- 3 Keep children away. Do not let visitors touch the tools or extension cord. All visitors should be kept away from work area.
- 4 Store idle tools. When not in use, tool should be stored in a dry locked up place, out of reach of children.
- 5 Do not force the tool. It will do the job better and safer at the rate for which it was intended.
- 6 Stay alert. Watch out what you are doing–Use common sense. Do not operate tool when you are tired. Check damaged parts. Before further use of the tool, a guard or other part is damaged should be carefully checked to determine that it will operate properly and perform its intended function.
- 7 Check for alignment of moving parts, blinding of moving parts, breakage of parts, mounting and any other condition that may affect its operation.
- 8 A guard or other parts that is damaged should be properly repaired or replaced by an authorized service center unless otherwise indicated in this instruction manual. Have defective switches replaced by an authorized service center. Do not use tool if switch does not turn it on.
- 9 To ensure the designed operational integrity of power tools, do not remove installed cover or screws.
- 10 Use your tool at lower input than specified on the nameplate, otherwise, the finish may be spoiled and working efficiency reduced by motor overload.
- 11 Do not wipe plastic parts with solvent. Solvents such as gasoline, thinner, benzene, carbon tetrachloride, alcohol, ammonia and oil containing chloric annex may damage and crack plastic parts. Do not wipe them with such solvent. Wipe plastic parts with a soft cloth lightly dampened with soap water.
- 12 Dress properly. Do not wear loose clothing or jewellery. Contain long hair keep your hair, clothing, and gloves away from moving parts.
- 13 Use safety equipment. Always wear eye protection, non-skid safety shoes, hard hat, or hearing protection.
- 14 Do not overreach. Proper footing and balance enables better control of the tool in unexpected situations.

PRODUCT SAFETY INSTRUCTIONS

- 1 Disconnect battery pack from tool or place the main switch in the locked or off position before making any adjustments, changing accessories, or storing the tool. Such preventative safety measures reduce the risk of starting the tool accidentally.
- 2 Remove adjusting keys or wrenches before turning the tool on. A wrench or a key that is left attached to a rotating part of the tool may result in personal injury.
- 3 Use clamps or other practical way to secure and support the work piece to a stable platform. Holding the work by hand or against your body is unstable and may lead to a loss of control.
- 4 Maintain tools with care. Keep cutting tools sharp and clean. Properly maintained tools, with sharp cutting edges are less likely to bind and are easier to control.
- 5 Use only accessories that are recommended by the manufacturer for your model. Accessories that may be suitable for one tool may create a risk of injury when used on another tool.

IMPORTANT SAFETY INSTRUCTIONS FOR CHARGER & BATTERY PACK

- 1 Caution: To reduce risk of injury, charge only specific type rechargeable battery packs. Other types of battery packs may burst causing personal injury and damage.
- 2 Before using charger, read all instructions and cautionary markings on battery packs and chargers.
- 3 Do not expose charger to rain or snow.
- 4 To reduce the risk of damage to electric plug and cord, pull by plug rather than cord when disconnecting charger.
- 5 Use of an attachment not recommended or sold by the charger manufacture may result in a risk of fire, electric shock, or injury to persons.
- 6 Make sure cord is located so that it will not be stepped on, tripped on, tripped over, or otherwise subjected damage or stress.
- 7 Do not operate charger with damaged cord or plug. Replace them immediately.
- 8 Do not operate charger if it has received a sharp blow, been dropped, or otherwise damaged in any way, take it to qualified center.
- 9 To reduce risk of electric shock, unplug charger from outlet before attempting any maintenance or cleaning. Turning off controls will not reduce this risk.
- 10 Do not disassemble charger or battery pack, take it to a qualified service center while repair is required. Incorrect reassembling may result in a risk of electric shock or fire.

ADDITIONAL SAFETY RULES FOR CHARGER & BATTERY PACK

- 1 Do not charge battery pack when temperature is below 10°C (50°F) or above 40°C (104°F).
- 2 Do not attempt to use a set-up transformer, an engine generator or DC power receptacle.
- 3 Do not allow anything to cover or clog the charger vents.
- 4 Always cover the battery pack terminals with the battery pack cover when the battery pack: is not used.
- 5 Do not short the battery pack.
- 6 Do not touch the terminals with any conductive material.
- 7 Avoid storing battery pack in a container with other metal objects such as nails, coins, etc.
- 8 Do not expose battery pack to water or rain, A battery pack short can use large current flow, overheating, possible burns and even a breakdown.
- 9 Do not store the machine and battery pack in locations where the temperature may reach or exceed 50°C (122°F)
- 10 Do not incinerate the battery pack even if it is severely damaged or completely worn out. The battery pack can explode in a fire.
- 11 Be careful not drop, shake or strike battery pack.
- 12 Do not charge inside a box or container of any kind. The battery pack must be placed in a well ventilated area during charging.
- 13 Do not leave batteries unused for extended period of time. Recharge the battery every 3–6 months and bring Li-Ion battery to 40–80% charge level before storage.
- 14 Li-Ion batteries are sensitive to high temperature and should be kept in a cool, dry and out of direct light exposure. Ideal temperature for operation and storage is below 25°C (77°F).
- 15 This product is designed with low voltage protection, which prevents the tool from over discharging and prolong battery's life span.

PRODUCT SPECIFICATIONS

Model No.	K 10618
Voltage	10.8V DC
No load speed/min	3200 rpm
Tool weight (with battery)	0.875 kg (battery 0.185 kg)
Charging Time	1 hour Auto Cut-Off

MAJOR COMPONENTS



ACCESSORIES



Charger K 10257



Polishing pad K 10620



Wrench K 10623

OPERATING INSTRUCTIONS

INSTALLING OR REMOVING BATTERY PACK

(See Fig.1 Fig.2)

- 1 Always switch off the machine before insertion or removal of the battery pack.
- 2 To remove the battery pack, pull out the set plate on the machine and grasp both sides of the battery pack while withdrawing it from the machine.
- 3 To insert the battery pack, align the tongue in the battery pack with the groove in the housing and slip it into place. Snap the set plate back into place. Be sure to close the set plate fully before using the machine.
- 4 Do not use force when inserting the battery pack. If the battery pack does not slide in easily, it is not being inserted correctly.

CHARGING THE BATTERY PACK

(See Fig.3)

- 1 Plug the fast charger into the power source.
- 2 Slide the battery pack into the charger as the arrow direction shown on the charger.
- 3 Push the battery pack into place and make sure the red light on the charger is "ON". The battery pack is now starting the charging cycle.
- 4 After finish the charging cycle, the light will turn into green. The battery pack is now ready for use.
- 5 Your new battery pack is not charged. You need to charge it before use.
- 6 Always use the specified charger to charge the battery. When the battery pack is inserted into the charger correctly, the red light will come on and charging will begin.
- 7 When you charge a new battery pack or a battery pack which has not been used for a long period, it may not accept a full charge. This is a normal condition and does not indicate a problem. You can recharge the battery pack fully after discharging it completely a couple of times.
- 8 Unplug the charger from the power source after finish the charge.
- 9 Please remove the battery from the unplugged charger for storage.

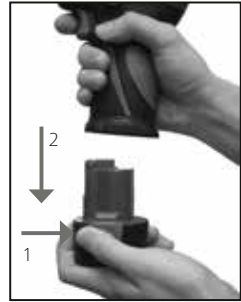

Fig 1



Fig 2



Fig 3

LED LIGHT ON THE CHARGER



Power On (Green light flashes slowly)



Battery low (Red light stays illuminated)



Battery charged 80% (Green light flashes rapidly)



Battery charged 100% (Green light stays illuminated)



Battery pack temperature is too hot or too cold
(Red light flashes slowly)



Battery pack malfunction
(Red and Green lights stay illuminated)



- 1 Charger can only be plugged into a 100-240V a.c outlet.
- 2 If the battery pack is too hot or too cold, the charger will not fast charge the battery pack and the red Indicator light is "blinking". When the battery pack temperature returns to between 0°C and 50°C, the charger will automatically begin charging.
- 3 If both red and green indicator lights are "ON" the battery pack either does not comply or is defective. Please contact your retailer.
- 4 Do not charge the battery pack in rain, snow or high temperature environment.
- 5 Do not charge battery pack when temperature is below 10°C (50°F) or above 40°C (104°F)
- 6 While charging a cool battery pack (below 5°C or 41°F) in warm indoor temperatures, keep the battery pack in the room for one hour to warm up before charging. A cool battery may charge unsaturated.
- 7 Remove the plug after finishing the charge.
- 8 Do not use generator for charging the battery pack

Tightening velcro pad attachment to the shaft
in clockwise direction

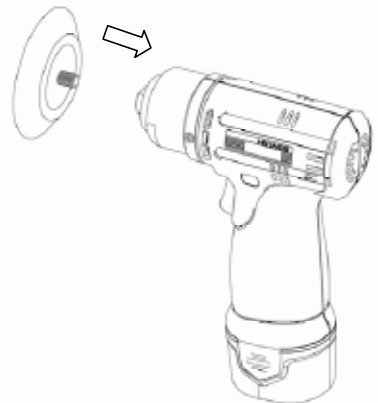



PARTS K 10618

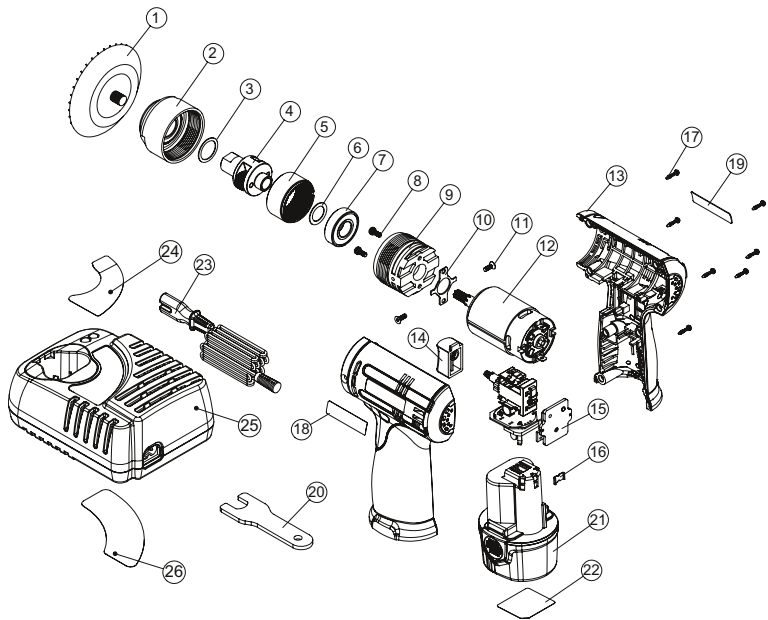

No	Parts name	Qt	Spare part No
1	Velcro pad	1	K 10620
2	Front cover ass'y	1	
3	Washer	1	
4	Bush ass'y	1	
5	Ring gear	1	
6	Washer	1	
7	Bearing	1	
8	Screw	2	
9	Motor fixity	1	
10	Washer	1	
11	Screw	2	
12	Motor ass'y	1	K 10621
13	Housing L&R	1	

No	Parts name	Qt	Spare part No
14	Trigger	1	
15	Main switch	1	K 10622
16	Housing clip	1	
17	Housing screw	7	
18	Housing label L	1	
19	Housing label R	1	
20	Wrench	1	K 10623
21	Battery pack	1	
22	Battery label	1	
23	Power cord	1	
24	Charger upper label	1	
25	Charger	1	
26	Charger lower label	1	

K 10618

www.kamasatools.com